

SG-2G-LED SMARTGATEWAY INSTALLATION

The LED smartgateway controls and dims smartengine ready 3rd party LED fixtures. The smartgateway is installed on or next to each fixture and communicates with and is powered by the smartengine via low-voltage cable. The smartgateway connects to smart sensor which collects light level, temperature and motion data, transmitting this data back to the smartengine.

The smartgateway accepts standard category 5e, 6 or 6a cable via RJ45 connectors or 18 AWG (1mm) via spring loaded terminal connectors. The smartgateway uses one, two or three “channels” to deliver power from the smartengine to the LED fixture depending on the fixture’s power requirements. Each channel provides 18-48Vf and 150-700mA.

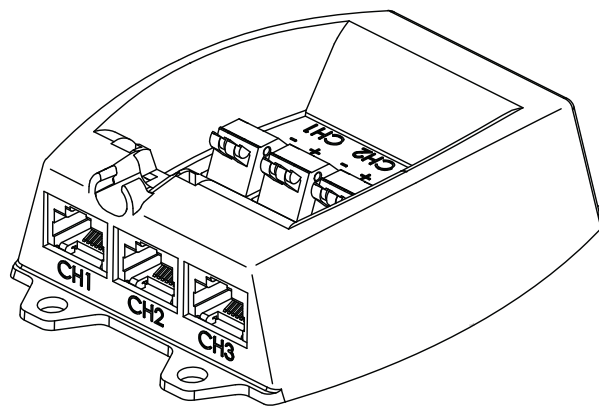

ORDERING INFORMATION

PART NO.	DESCRIPTION
SG-2G-LED-GNEW2350	LED Gateway, two channel 350–700 mA fixture
SG-2G-LED-GNEW3350	LED Gateway, three channel 350–700 mA fixture

IMPORTANT

- Do NOT place the gateway in a location where it will get hotter than 50°C.
- The smart sensors have been tested by UL to UL2043 which ensures low smoke-emitting characteristics and suitable fire resistance for equipment that may be installed in environmental air-handling spaces, as described in Article 300.22(c) of the NEC (2008).
- When the product is installed in air-handling spaces, such as above some suspended ceilings, the cabling employed should be suitable under NEC (2008) Article 800.154 and marked accordingly for use in plenums and air-handling spaces with regard to smoke propagation, such as CMP. The products and wiring should be installed in accordance with all applicable local regulations and practices.
- Verify that the supplied RJ25 cable that came with the smart sensor is used to connect it to the smart gateway.
- Always connect the smart sensor cable to the correct connector on the smart gateway.

SG-2G-LED SMARTGATEWAY INSTALLATION

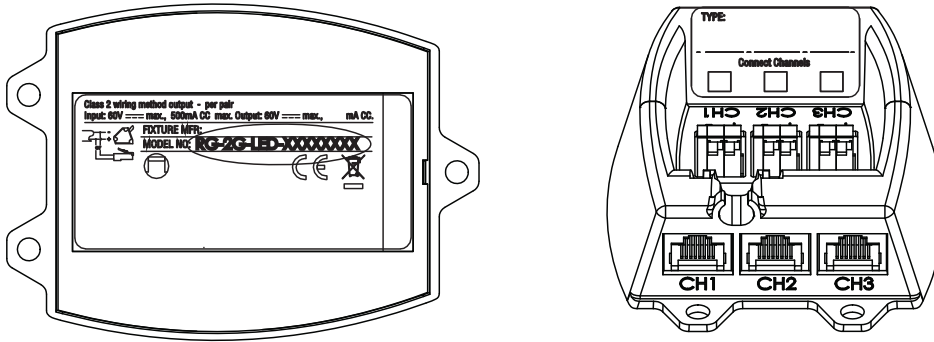

Location of LED smartgateway model number for fixture installation and channel connection

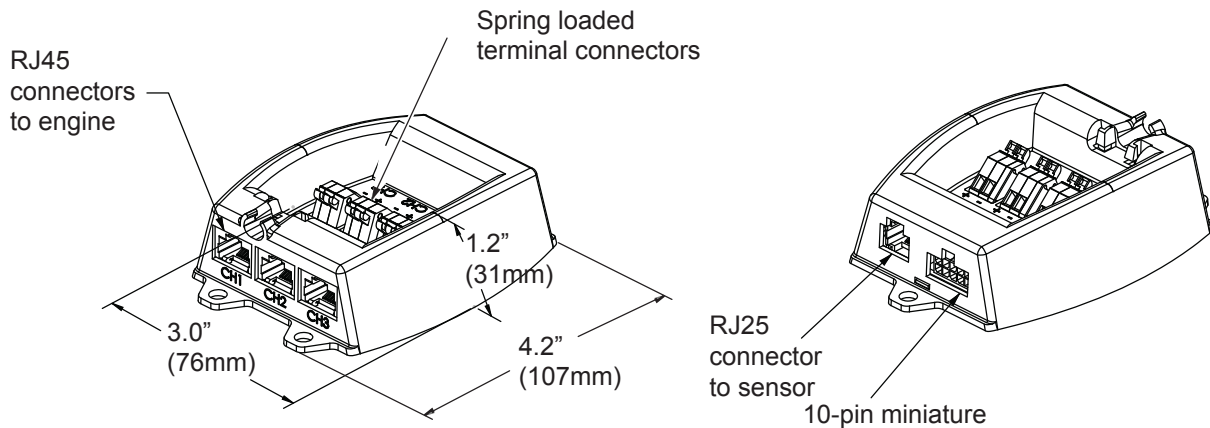

SG-2G-LED SMARTGATEWAY INSTALLATION

STEP 1 - CONNECT SMARTGATEWAY TO SMARTENGINE

FOR CATEGORY CABLING:

Connect the LED smartgateway to the smartengine with RJ45 connector(s) for category cabling to each channel. Proceed to Step 2.

FOR 18 AWG (1MM) WIRING:

Connect the LED smartgateway to the smartengine using the spring loaded terminal connectors to insert low-voltage 18 AWG (1mm) wiring for each channel. Proceed to Step 2.

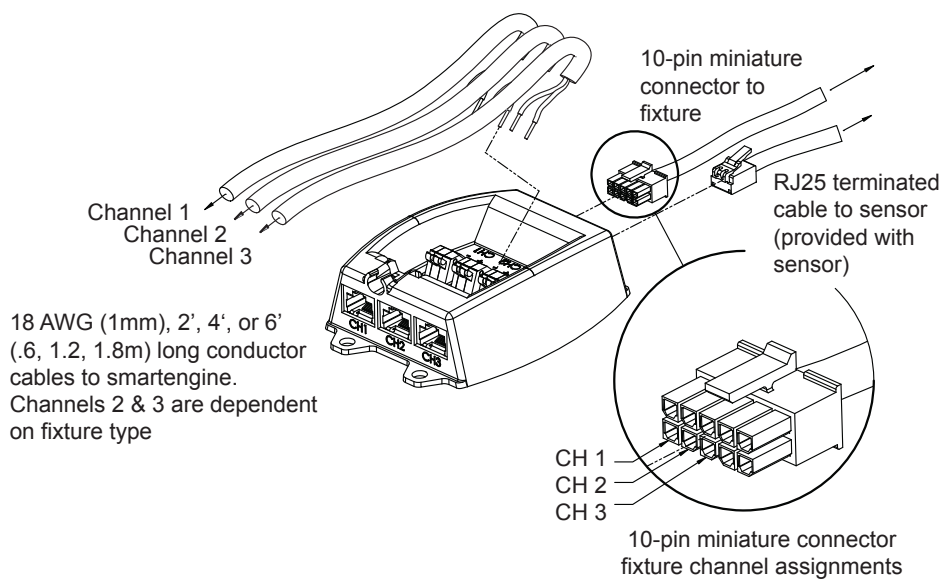
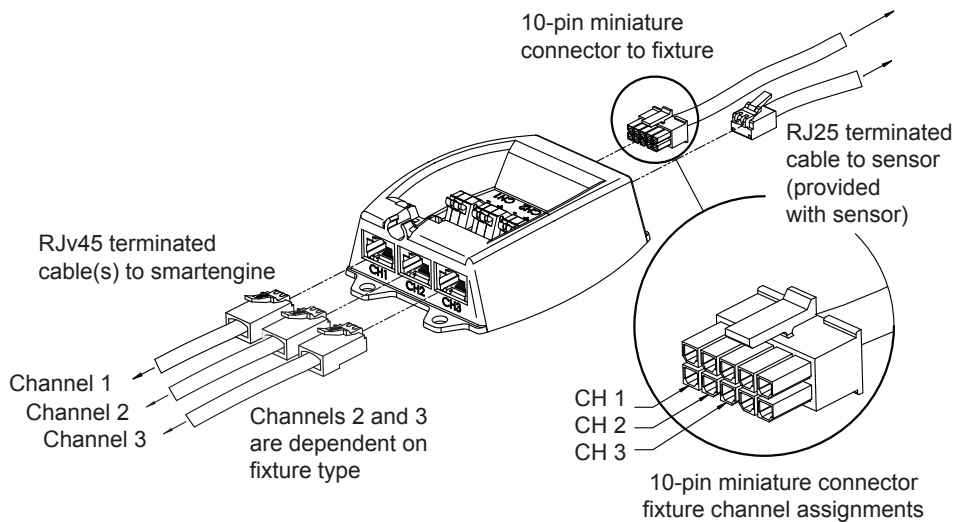

SG-2G-LED SMARTGATEWAY INSTALLATION

STEP 2 - CONNECT SMARTGATEWAY TO SMARTFIXTURE AND SMARTSENSOR

1. Connect the smartfixture to the LED smartgateway using the LED gateway harness
2. Connect the LED smartgateway to the smartsensor with the RJ25 cable.

STEP 3 - MOUNT SMARTGATEWAY

1. The smartgateway should be securely mounted to part of the building structure that does not exceed the mechanical specifications for the smartgateway. Note that the smartgateway must be within 6 feet of the smartsensor.
2. For drop wire mounting, the Caddy® multi-function Z-Clip, Part #170650, Description 4Z34 is recommended. Supports #10-24 and 1/4-20 threaded bridle rings and attaches to #12 wire through 1/4" rod.

